

MILLER TYPE FEEDER

CONSTRUCTION DETAILS FOR 3/4" THICK LUMBER

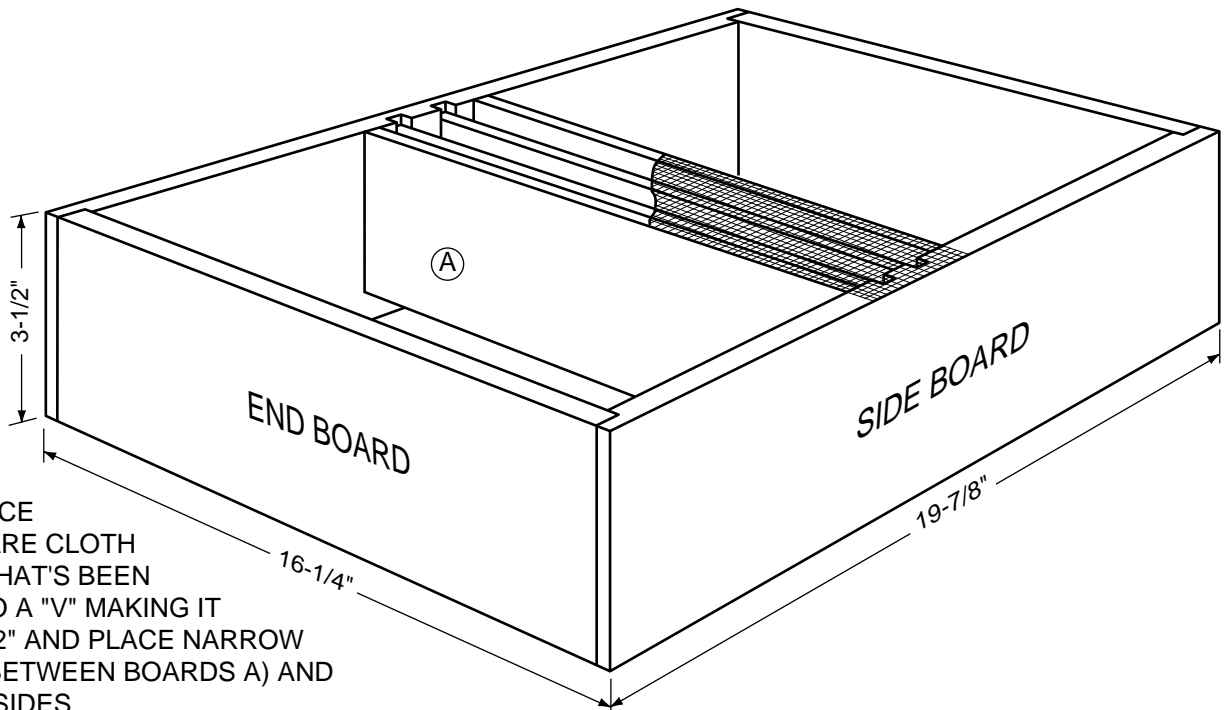

PLACE 1) PIECE
1/8" HARDWARE CLOTH
5" X 14-1/2" THAT'S BEEN
FOLDED INTO A "V" MAKING IT
2-1/2" X 14-1/2" AND PLACE NARROW
END DOWN BETWEEN BOARDS A) AND
B) ON BOTH SIDES.

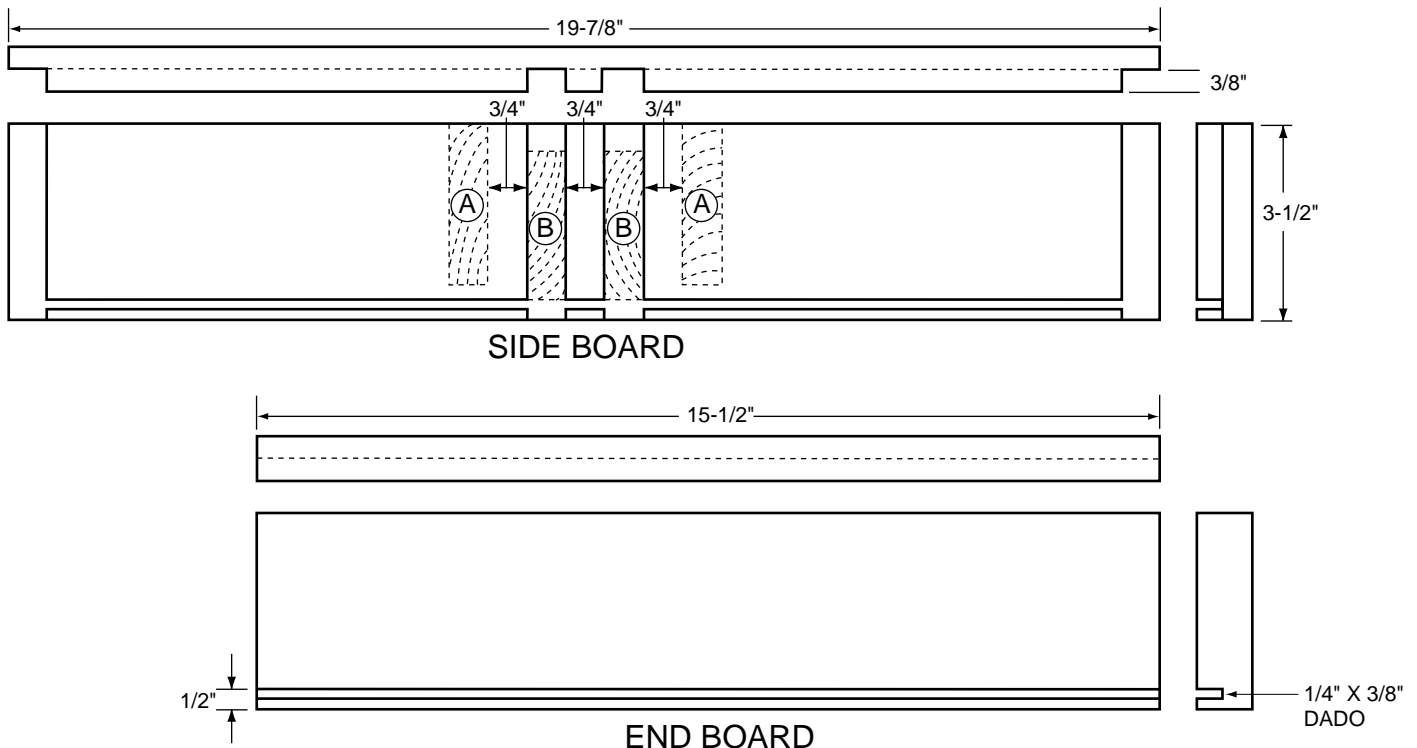

MATERIAL LIST:

- 2) SIDE BOARDS 3/4" X 3-1/2" X 19-7/8"
- 2) END BOARDS 3/4" X 3-1/2" X 15-1/2"
- 2) BOARD "A" 3/4" X 2-5/8" X 14-3/4"
- 2) BOARD "B" 3/4" X 2-1/2" X 15-1/2"
- 2) BOTTOM BOARDS 1/4" X 9-1/4" X 15-1/2" LUAN PLY.
- 1) PIECE 1/8" HARDWARE CLOTH 5" X 16-1/4"

GIVE ENTIRE INSIDE OF FEEDER TWO COATS OF POLYURETHANE OR MARINE VARNISH. POUR MOLTEN WAX ONTO ALL INSIDE SEAMS. ATTACH HARDWARE CLOTH TO TOP OF BOARDS "A" WITH STAPLES.

©.1999.BeeSource.com - All Rights Reserved.
info@beesource.com/www.beesource.com
Reproduction for personal and non-profit use only.